

CBES-Liquid Cooled AC/DC Integrated Outdoor Cabin

Highly integrated, efficient and convenient

The liquid cooled AC/DC integrated outdoor cabin adopts modular integrated design and can reach 400V AC output, flexibly adapting to different scenarios. It meets the needs of peak shaving and load shifting, dynamic capacity expansion, demand response, backup power supply and microgrid.



Security and Stability

- The life cycle of the liquid cooling medium is more than 10 years, ensuring the reliable operation of the system.
- Dual FSS, combustible gas detection / exhaust / explosion proof design / re-ignition prevention.



Smart and Efficient

- Efficient and reliable liquid cooling system, powered by interconnected between thermal management system and BMS, helps reduce auxiliary energy consumption.
- Real-time accurate temperature monitor and control, ensures cell temperature difference $\leq 3^{\circ}\text{C}$, improve the consistency of the cell.



Highly Integrated

- Modular design. 400V AC output.
- Flexibly fit in different scenarios and support a maximum of 20 parallel machines.



Easy Maintenance

- Remote upgrade / APP operation and maintenance / cloud-edge collaboration.
- Support life cycle system fault diagnosis, battery health assessment and early warning.



Peak shaving and load shifting



Dynamic expansion



Demand response



Standby power supply



Microgrid

Technical Data	CBES-125kW/261kWh
-----------------------	--------------------------

DC	
Cell Type	LFP 3.2V/314Ah
System Configuration	1×1P260S
Rated Power	125/261KWh
Grid-tied AC output	Grid-tied AC output
Rated Charging/Discharging Power	125kW
Rated Voltage	AC400V
Rated Frequency	50Hz/60 Hz
Off-grid AC output	
Rated Output Power	125kW
Rated Output Voltage	AC400V
Rated Output Frequency	50Hz/60Hz
Unbalanced Load Capacity	100%
General	
Dimensions(W×D×H)	1100*1350*2350mm
Weight	3t
Operating Temperature	-20°C~+50°C
Relative Humidity	0-95% (No condensation)
Cooling Method	Liquid cooling
Noise Level	≤80dB
Fire Suppression System	Aerosol
Communication Interface	Ethernet
Communication Protocol	Modbus TCP/IP
Code & Compliance	GB/T36276、IEC62619

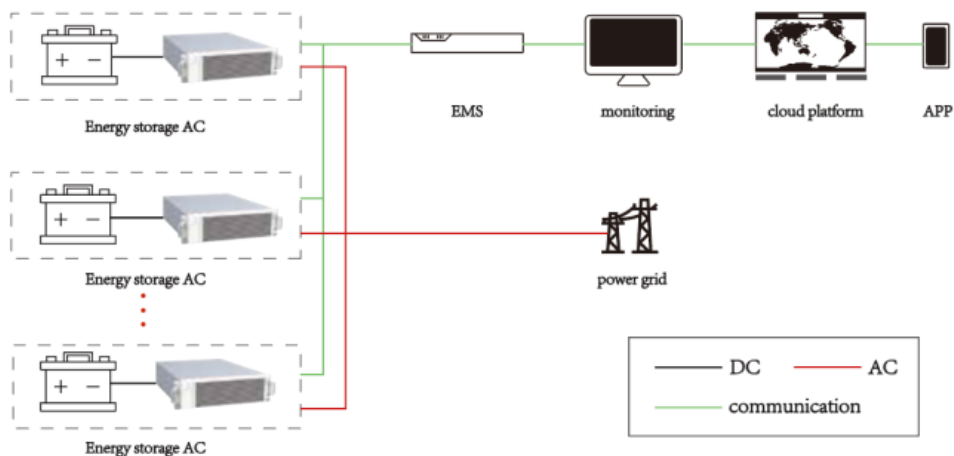

Specification are subject to change without notice due to continuous development.