

Overview

The rechargeable batteries are lead-lead dioxide systems. The dilute sulfuric acid electrolyte is absorbed by separators and plates and thus immobilized. Should the battery be accidentally overcharged producing hydrogen and oxygen, special oneway valves allow the gases to escape thus avoiding excessive pressure build-up. Otherwise, the battery is completely sealed and is, therefore, maintenance-free, leak proof and usable in any position.

Battery Construction

Component	Positive plate	Negative plate	Container	Cover	Safety valve	Terminal	Separator	Electrolyte
Raw material	Lead dioxide	Lead	ABS	ABS	Rubber	Copper	Fiberglass	Sulfuric acid

General Features

- Positive and negative plates in lead-calcium-tin alloy;
- Stable Quality&High Reliability;
- Sealed Construction;
- Long Service Life;
- Maintenance-Free Operation;
- Low Pressure Venting System;
- Low Self Discharge;
- U.L.Component Recognition;
- Six months shelf life at 20°C;
- Design life 10 years

Battery Specification

Performance Characteristics	
Nominal Voltage	12V
Number of cell	6
Design Life	10 years
Nominal Capacity 77°F(25°C)	
10 hour rate (10.0A, 10.8V)	100Ah
5 hour rate (17.5A, 10.5V)	87.5Ah
1 hour rate (66.2A, 9.6V)	66.2Ah
Internal Resistance	
Fully Charged battery 77°F(25°C)	≤5.7 mOhms
Self-Discharge	
3% of capacity declined per month at 20°C (average)	
Operating Temperature Range	
Discharge	-20~60°C
Charge	-10~60°C
Storage	-20~60°C
Max. Discharge Current 77°F(25°C)	900A(5s)
Short Circuit Current	2100A
Charge Methods: Constant Voltage Charge 77°F(25°C)	
Cycle use	2.40-2.45VPC
Maximum charging current	30.0A
Temperature compensation	-30mV/°C
Standby use	2.20-2.30VPC
Temperature compensation	-20mV/°C

Dimensions and Weight

Length(mm / inch)	330 / 13.0
Width(mm / inch)	171 / 6.73
Height(mm / inch)	215 / 8.46
Total Height(mm / inch)	222 / 8.74
Approx. Weight(Kg / lbs)	32.0 / 70.6

* Weight deviation: ± 5%

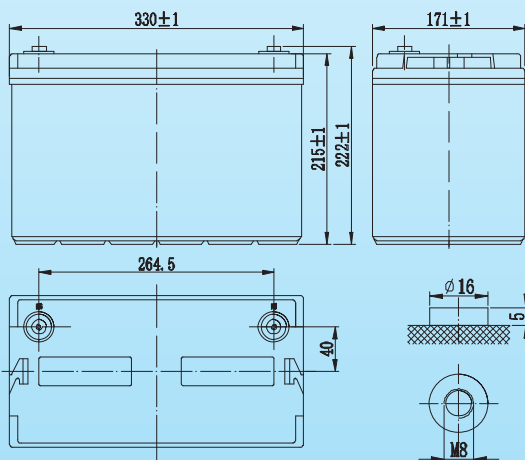

Discharge Constant Current (Amperes at 77°F25°C)

End Point Volts/Cell	Time							
	10min	15min	30min	1h	3h	5h	10h	24h
1.60V	229	185	108	66.2	27.9	19.0	10.8	4.70
1.65V	221	178	104	62.5	27.7	18.3	10.6	4.68
1.70V	200	164	96.0	61.5	27.2	18.0	10.5	4.59
1.75V	187	153	93.0	60.5	26.9	17.5	10.3	4.50
1.80V	175	143	91.0	57.4	25.3	17.2	10.0	4.42

Discharge Constant Power (Watts at 77°F25°C)

End Point Volts/Cell	Time							
	10min	15min	30min	45min	1h	3h	5h	10h
1.60V	392	321	199	150	124	52.8	35.8	20.3
1.65V	379	315	188	146	118	51.2	35.4	20.1
1.70V	360	299	183	137	114	50.9	35.0	20.0
1.75V	353	294	177	134	111	49.1	34.4	19.6
1.80V	329	279	171	131	104	48.5	34.0	19.1

(Note)The above characteristics data are average values obtained within three charge/discharge cycles not the minimum values.All data shall be changed without notice, Vision reserves the right to explain and update the information contained hereinto.



VISION GROUP
Shenzhen Center Power
Tech.Co.Ltd.,

6FM100-X

12V 100Ah(10hr)

