

Overview

The rechargeable batteries are lead-lead dioxide systems. The dilute sulfuric acid electrolyte is absorbed by separators and plates and thus immobilized. Should the battery be accidentally overcharged producing hydrogen and oxygen, special oneway valves allow the gases to escape thus avoiding excessive pressure build-up. Otherwise, the battery is completely sealed and is, therefore, maintenance-free, leak proof and usable in any position.

Battery Construction

Component	Positive plate	Negative plate	Container	Cover	Safety valve	Terminal	Separator	Electrolyte
Raw material	Lead dioxide	Lead	ABS	ABS	Rubber	Copper	Fiberglass	Sulfuric acid

General Features

- Absorbent Glass Mat (AGM) technology for efficient gas recombination of up to 99% and freedom from electrolyte maintenance or water adding.
- Not restricted for air transport-complies with IATA/ICAO Special Provision A67.
- UL-recognized component.
- Can be mounted in any orientation.
- Computer designed lead, calcium tin alloy grid for high power density.
- Long service life, float or cyclic applications.
- Maintenance-free operation.
- Low self discharge.
- Case and cover available in both standard and flame retardant ABS.

Dimensions and Weight

Length(mm / inch)	436 / 17.2
Width(mm / inch)	108 / 4.25
Height(mm / inch)	317 / 12.5
Total Height(mm / inch)	317 / 12.5
Approx. Weight(Kg / lbs)	36.0 / 79.4

* Weight deviation: ± 3%

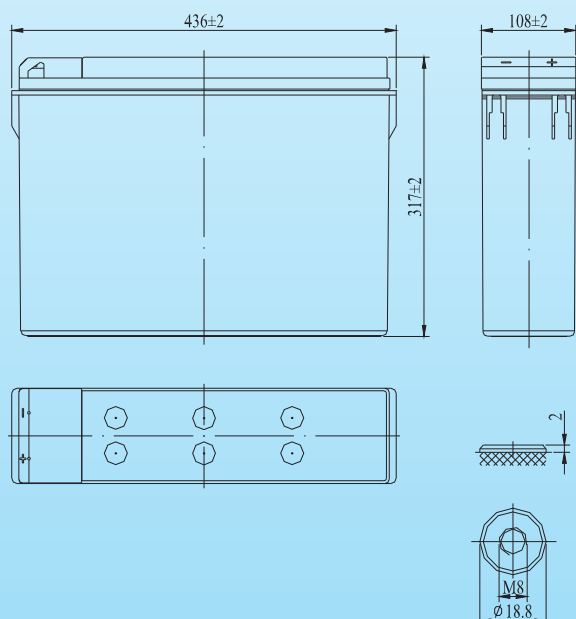

Battery Specification

Performance Characteristics	
Nominal Voltage	12V
Number of cell	6
Design Life	10years
Nominal Capacity 77°F(25°C)	
10 hour rate (12.5A, 10.8V)	125Ah
5 hour rate (23.0A, 10.5V)	115Ah
1 hour rate (85A, 9.6V)	85Ah
Internal Resistance	
Fully Charged battery 77°F (25°C)	≤6.3mOhms
Self-Discharge	
3% of capacity declined per month at 20°C(average)	
Operating Temperature Range	
Discharge	-20~60°C
Charge	-10~60°C
Storage	-20~60°C
Max. Discharge Current 77°F(25°C)	950A(5s)
Short Circuit Current	2250A
Charge Methods: Constant Voltage Charge77°F(25°C)	
Cycle use	2.40-2.45VPC
Maximum charging current	37.5A
Temperature compensation	-30mV/°C
Standby use	2.20-2.30VPC
Temperature compensation	-20mV/°C

Discharge Constant Current (Amperes at 77°F25°C)

End Point								
Volts/Cell	10min	15min	30min	45min	1h	3h	5h	10h
1.60V	--	--	138	103	85.0	35.2	23.5	12.9
1.65V	--	--	134	101	83.8	34.9	23.3	12.8
1.70V	--	--	131	99.0	82.5	34.6	23.2	12.7
1.75V	--	--	127	97.0	81.3	34.3	23.0	12.6
1.80V	--	--	123	95.0	80.0	34.0	22.8	12.5

Discharge Constant Power (Watts at 77°F25°C)

End Point								
Volts/Cell	10min	15min	30min	45min	1h	2h	3h	5h
1.60V	--	--	252	192	157	90.8	66.1	44.2
1.65V	--	--	246	188	154	89.3	65.4	43.9
1.70V	--	--	239	184	150	87.9	64.7	43.6
1.75V	--	--	232	179	147	86.4	63.9	43.2
1.80V	--	--	225	175	144	85.0	63.2	42.9

(Note)The above characteristics data are average values obtained within three charge/discharge cycles not the minimum values.All data shall be changed without notice, Vision reserves the right to explain and update the information contained hereinto.



VISION GROUP
Shenzhen Center Power
Tech.Co.Ltd.,

CT12-125EX

12V125Ah(10hr)

